

USER MANUAL

1000R AND 2200R SERIES

RACKMOUNTED UNINTERRUPTIBLE POWER SUPPLY



MODEL NUMBERS

- UPS-1000R
- UPS-1000R-IP
- UPS-1000R-8IP
- UPS-2200R
- UPS-2200R-IP
- UPS-2200R-8IP

THANK YOU

Thank you for purchasing the 1000R or 2200R Series Rackmounted UPS. The UPS provides battery backup during power outages, automatic voltage regulation during periods of inconsistent utility power and surge protection.

IMPORTANT

Please read this manual before removing the UPS from the shipping carton and before making any connections to and operating your UPS.



TABLE OF CONTENTS

Important Safety Instructions	3 - 4
Middle Atlantic Products Green Power UPS Technology	5
FCC Warning	5 - 6
Circuit Diagram	6
Unpacking and Parts List	7
Installation and Mounting	7 - 8
Front Panel Descriptions	9
Rear Panel Descriptions (Bank Outlets)	9 - 10
Rear Panel Descriptions (Individual Outlets)	11 - 12
Setup Of (NIC) UPS-IPCARD	13 - 15
LCD Display Definitions	16
Battery Charging	17
Self Test	17
EPO (Emergency Power Off) Port Connection	17
Operation	18
General Status Mode	19
Functions Setup Mode	19 - 20
Battery Replacement	21 - 24
Optional External Battery Connection	24
Troubleshooting	25 - 26
Technical Specifications	27 - 28
Estimated Runtime	28 - 29
Warranty	29
Warranty Registration	30



IMPORTANT SAFETY INSTRUCTIONS READ AND SAVE THESE INSTRUCTIONS



This manual contains important instructions that should be followed during installation and maintenance of the UPS and batteries.



The lightning flash with the arrowhead symbol, within an equilateral triangle, is intended to alert the user to the presence of uninsulated dangerous voltage within the product's enclosure that may be of sufficient magnitude to constitute a risk of electric shock.



The exclamation point within an equilateral triangle is intended to alert the user to the presence of important operating and maintenance (servicing) instructions in the literature accompanying the product.



WARNING: The UPS must be connected to a grounded AC power outlet with fuse or circuit breaker protection. DO NOT plug the UPS into an outlet that is not grounded. If you need to de-energize this equipment, turn off and unplug the UPS.



WARNING: The internal battery in this UPS is always charged. The battery can energize hazardous live parts inside the unit, even when the AC input power is disconnected.



WARNING: To prevent the risk of fire or electric shock, install in a temperature and humidity controlled indoor area, free of conductive contaminants. (Please see specifications for acceptable temperature and humidity range).



WARNING: To reduce the risk of electric shock, do not remove the cover, except to service the battery. There are no serviceable parts inside, except for the battery.



WARNING: To avoid electric shock, turn off the unit and unplug it from the AC power before servicing the battery or installing a component.



WARNING: Do not use for medical or life support equipment. Do not use in any circumstance that would affect operation or safety of any life support equipment, with any medical applications, or patient care.



WARNING: Risk of battery explosion, if battery is replaced by an incorrect type or rating.



WARNING: Do not open or mutilate the batteries. Electrolyte is harmful to the skin and eyes and may be toxic.



WARNING: A battery can present a high risk of short circuit current or electrical shock.



WARNING: The battery may present the risk of electrical shock. Do not dispose of batteries in a fire, as they may explode. Follow all local ordinances regarding proper disposal of batteries.



CAUTION: Risk of energy hazard, 12V, 9AH battery. Before replacing batteries, remove conductive jewelry such as chains, wrist watches, and rings. High energy through conductive materials could cause severe burns.



CAUTION: To reduce the risk of fire, connect only to a circuit provided with 20 Amperes maximum branch overcurrent protection in accordance with the National Electrical Code, ANDI/NFPA 70.



CAUTION: Use only the specified type of battery. See your dealer for replacement batteries.



CAUTION: For PLUGGABLE EQUIPMENT, the socket-outlet shall be installed near the equipment





CONSIGNES DE SÉCURITÉ IMPORTANTES LIRE ET CONSERVER CES INSTRUCTIONS



Ce manuel contient des instructions importantes à suivre lors de l'installation et de la maintenance de l'onduleur et des batteries.

 L'éclair avec le symbole de flèche dans un triangle équilatéral est destiné à alerter l'utilisateur de la présence d'une tension dangereuse non isolée dans l'enceinte du produit qui peut être d'une ampleur suffisante pour constituer un risque de choc électrique pour les personnes

 Le point d'exclamation dans un triangle équilatéral est destiné à alerter l'utilisateur de la présence d'importants instructions d'opération et de maintenance (entretien) dans la documentation accompagnant l'appareil

 **AVERTISSEMENT:** L'onduleur doit être branché sur une prise de courant alternatif protégée par un fusible ou un disjoncteur. Ne branchez pas le UPS dans une prise qui ne sont pas mis à la terre. Si vous avez besoin de mettre hors tension de cet équipement, éteindre et de débrancher l'onduleur.

 **AVERTISSEMENT:** Même lorsque le cordon d'alimentation est débranché, les parties internes peuvent recevoir suffisamment de courant de la batterie pour être dangereuses.

 **AVERTISSEMENT:** Pour éviter les risque d'incendie ou de choc électrique, l'appareil doit être installé dans un local libre de contaminants conducteurs et dont la température et l'humidité sont contrôlées (reportez-vous aux spécifications techniques pour prendre connaissance des plages de température et d'humidité acceptables).

 **AVERTISSEMENT:** Pour réduire le risque de choc électrique, ne pas enlever le couvercle, à l'exception de réparer la batterie. Il n'y a pas de pièces réparables par l'intérieur, sauf pour la batterie.

 **AVERTISSEMENT:** Pour éviter la décharge électrique, éteignez arrêtez l'unité et débranchez-la de la source de courant alternatif avant d'entretenir la batterie.

 **AVERTISSEMENT:** Ne pas utiliser pour l'équipement de soutien médical ou de la vie. Ne pas utiliser en toute circonstance susceptible d'affecter fonctionnement ou la sécurité de tout le matériel de soutien de la vie, avec toutes les applications médicales ou les soins aux patients.

 **AVERTISSEMENT:** Risque d'explosion de la batterie, si la batterie est remplacée par un type incorrect ou d'une qualification.

 **AVERTISSEMENT:** N'ouvrez pas ou ne mutilez pas les batteries. Le matériel libéré est nocif à la peau et aux yeux et peut être toxique.

 **AVERTISSEMENT:** Une batterie peut présenter un risque élevé de courant de court-circuit ou un choc électrique.

 **AVERTISSEMENT:** La batterie peut présenter un risque de choc électrique. Ne jetez pas les batteries au feu, car elles peuvent exploser. Suivez tous les règlements locaux concernant l'élimination adéquate des piles.

 **ATTENTION:** Risque de danger énergétique, batterie 12V, 9AH. Avant de remplacer les piles, retirez les bijoux conducteurs tels que les chaînes, les montres-bracelets et les bagues. Une énergie élevée à travers des matériaux conducteurs peut provoquer de graves brûlures.

 **ATTENTION:** Pour réduire le risque d'incendie, reliez seulement à un circuit équipé de 20 ampères de branche de circuit de protection maximum de surintensité selon le code électrique national, ANSI/NFPA 70.

 **ATTENTION:** Utilisez uniquement le type de pile spécifié. Voir votre concessionnaire pour les batteries de remplacement.

 **ATTENTION:** Pour les appareils raccordés, la prise de courant doit être installée près de l'équipement et doit être facilement accessible.

MIDDLE ATLANTIC PRODUCTS GREEN POWER UPS TECHNOLOGY



Our new UPS circuit is designed to save energy operating in Green Power Bypass Mode.

A traditional UPS circuit with Automatic Voltage Regulation (AVR) provides normal output voltage through the relay and AVR transformer. The current travels first through the transformer conducting energy and generating heat. This heat creates energy dissipation resulting in a "Power Loss" or consumption of utility power and money.

Middle Atlantic Product's Green Power circuit design is a solution to this "Power Loss". When the utility power is operating normally, our Green Power UPS works in Bypass Mode. Our Green Power design conducts power only through the relay and still provides normal output voltage. Bypassing the transformer reduces power consumption thereby conserving energy and saving money. When the utility power is abnormal the UPS will operate under Battery or AVR Mode. Under this condition, Green Power UPS and a traditional UPS would operate about the same. On average, utility power operates 88% of the time and the Middle Atlantic Products Green Power Technology will work in its money/energy saving Bypass Mode.

FCC WARNING

NOTE: This equipment has been tested and found to comply with the limits for a Class B digital device, pursuant to Part 15 of the FCC Rules. These limits are designed to provide reasonable protection against harmful interference in a residential installation. This equipment generates, uses and can radiate radio frequency energy and, if not installed and used in accordance with the instructions, may cause harmful interference to radio communications. However, there is no guarantee that interference will not occur in a particular installation. If this equipment does cause harmful interference to radio or television reception, which can be determined by turning the equipment off and on, the user is encouraged to try to correct the interference by one or more of the following measures:

1. Reorient or relocate the receiving antenna.
2. Increase the separation between the equipment and receiver.
3. Connect the equipment into an outlet on a circuit different from that to which the receiver is connected.
4. Consult the dealer or an experienced radio/TV technician for help.

WARNING: A shielded-type power cord is required in order to meet FCC emission limits and also to prevent interference to the nearby radio and television reception. It is essential that only the supplied power cord be used. Use only shielded cables to connect I/O devices to this equipment.

WARNING: Any changes or modifications not expressly approved by the guarantee of this device could void the user's authority to operate the equipment.

FCC WARNING (CONTINUED)

REMARQUE: Cet appareil a subi des tests de contrôle et a été déclaré conforme aux limites imposées aux appareils numériques de Classe B par la section 15 de la réglementation FCC. Ces limites ont été établies pour assurer une protection raisonnable contre les interférences indésirables lorsque l'appareil fonctionne dans un environnement résidentiel. Cet appareil génère, exploite et peut émettre un rayonnement de fréquence radio. En outre, en cas d'installation et d'utilisation non conforme aux instructions, il risque de provoquer des interférences indésirables avec les transmissions radio. Rien ne garantit qu'aucune interférence ne se produira dans une installation donnée. Si l'utilisation de cet appareil provoque des interférences indésirables avec la réception radio ou télévision (ce que vous pouvez déterminer en l'éteignant, puis en le rallumant), il est recommandé d'essayer d'y remédier en prenant une ou plusieurs des mesures suivantes :

1. Réorientez ou déplacez l'antenne de réception.
2. Augmentez la distance entre l'appareil et le récepteur.
3. Branchez l'appareil sur une prise de courant située sur un circuit différent de celui du récepteur.
4. Contactez votre détaillant ou un technicien qualifié en réparation radio/télévision. Si un accessoire spécifique est nécessaire pour assurer la conformité de l'appareil, cela doit être précisé dans les instructions.

ATTENTION: Un cordon d'alimentation blindé est nécessaire pour respecter les limites d'émission fixées par la FCC et pour empêcher les interférences avec les récepteurs radio ou télévision placés à proximité. Il est impératif de n'utiliser que le cordon d'alimentation fourni. Ne connectez de périphériques d'entrée/sortie à cet appareil qu'avec des câbles blindés.

ATTENTION: Toute modification apportée à ce produit qui n'est pas expressément approuvée par la garantie peut priver l'utilisateur de son droit d'utiliser l'appareil.

CIRCUIT DIAGRAM

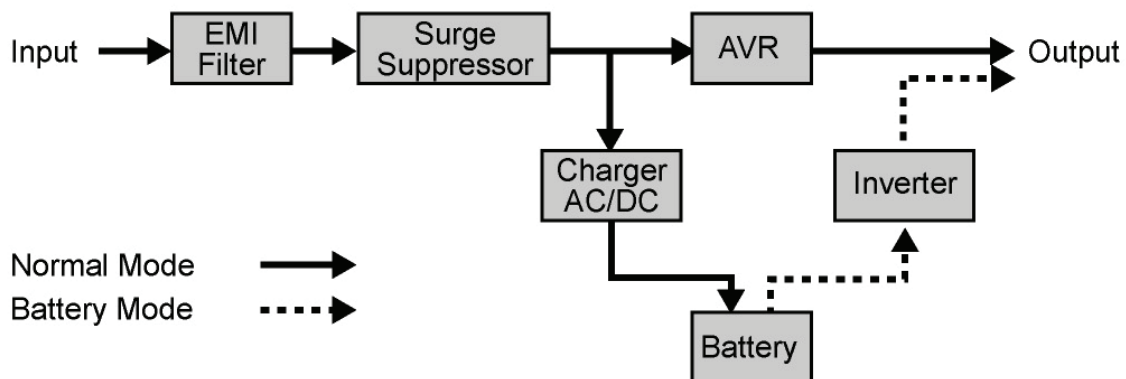

UNPACKING AND PARTS LIST



CAUTION: DO NOT LIFT THE UPS WHILE HOLDING THE FRONT FACE OF THE UNIT. THIS MAY DAMAGE THE UNIT. ALWAYS LIFT THE UPS BY HOLDING IT BY BOTH SIDES.



ATTENTION: NE SOULEVEZ PAS L'UPS PAR LE FRONT DE L'UNITÉ COMME CELA PEUT ENTRAÎNER DOMMAGES. TOUJOURS SOULEVER UNITÉ DES DEUX CÔTÉS.

LIFT OUT OF BOX
WHILE HOLDING
BOTH SIDES OF
UPS

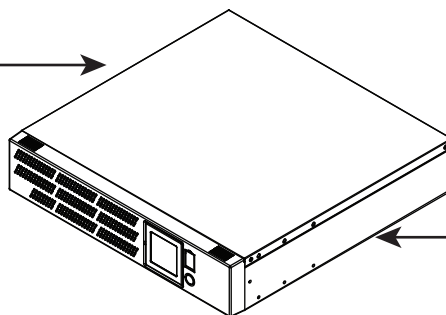

LIFT OUT OF BOX
WHILE HOLDING
BOTH SIDES OF
UPS

The UPS is very heavy and should be handled by two (2) people. After the product is removed from its shipping carton, inspect the UPS before installing and operating. The shipping carton should contain the following items:

- (1) UPS unit; (1) User's Manual; (2) Rack ears; (14) 10-32 Rack ear screws; (8) Nylon rivets (Used to plug four front screw holes for mounting ears if the unit will not be rack mounted);
- (1) Telephone Cable (black); (2) Rackmount handles; (4) 8-32 Rackmount handle screws;
- (1) Emergency Power Off Cable (gray); (1) Middle Atlantic Power Manager Software CD;
- (2) Serial Interface Cable (DB-9); (1) USB cable; (1) Warranty Registration Card

INSTALLATION AND MOUNTING

- 1) If using the provided handles install them now using provided 8-32 screws. **(FIGURE A)**

NOTE: The handles cannot be installed after the unit is rack-mounted.

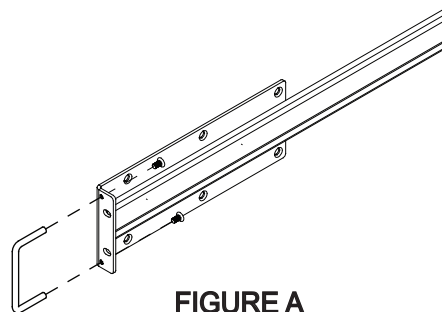
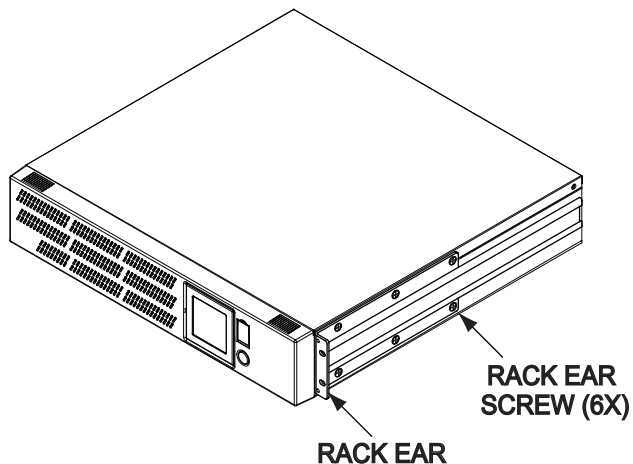

FIGURE A

- 2) Install ears as shown using provided 10-32 screws. Six screws per ear, one ear per side.



INSTALLATION AND MOUNTING (CONTINUED)



CAUTION: THIS UNIT IS HEAVY, LIFT CAREFULLY



**ATTENTION: CET APPAREIL EST LOURD,
SOULEVEZ AVEC ATTENTION**



One Person Installation:

- 1) Determine mounting location.
- 2) Install the Rear Mounting Brackets as shown. One Bracket is longer than the other to provide guidance when doing a one person installation. These brackets are interchangeable. **(FIGURE A)**
IMPORTANT NOTE: Rear Mounting Brackets mount between the two corresponding rackspaces in the front of the enclosure. **(FIGURE B)**
- 3) Carefully lift the unit to the mounting position constantly supporting the bottom. Place the slide on the unit's ear onto the longer Rear Mounting Bracket then guide the unit onto the other Rear Mounting Bracket. Once the ears and the Rear Mounting Brackets are fully engaged, slide to unit to the back of the enclosure.
- 4) Install the front of the unit to the rackrail. **(FIGURE C)**

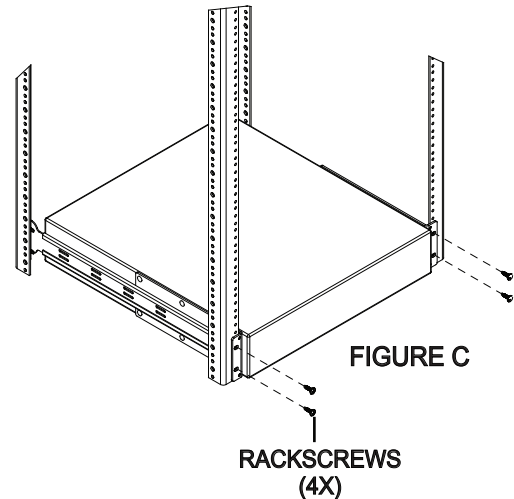
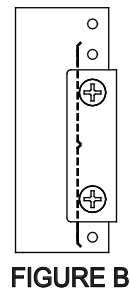
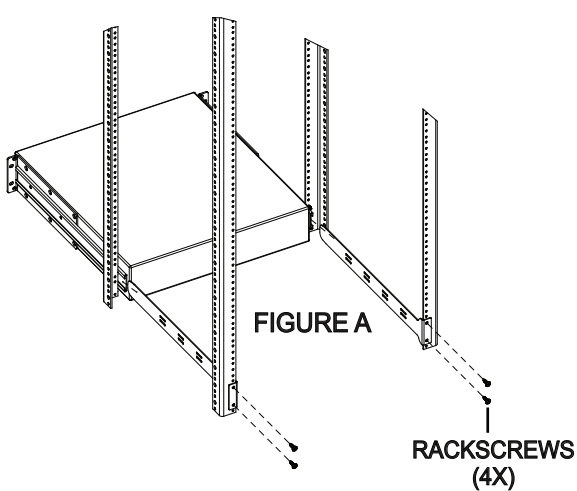

Two Person Installation:

- 1) Determine mounting location.
- 2) Properly support the unit from the bottom and carefully lift to the mounting location.
- 3) While adequately supporting the bottom, install the front of the unit to the rackrail. **(FIGURE D)**
- 4) Install the Rear Mounting Brackets as shown. Continue to support the bottom of the unit. **(FIGURE E)**
IMPORTANT NOTE: Rear Mounting Brackets mount between the two corresponding rackspaces in the front of the enclosure. **(FIGURE B)**

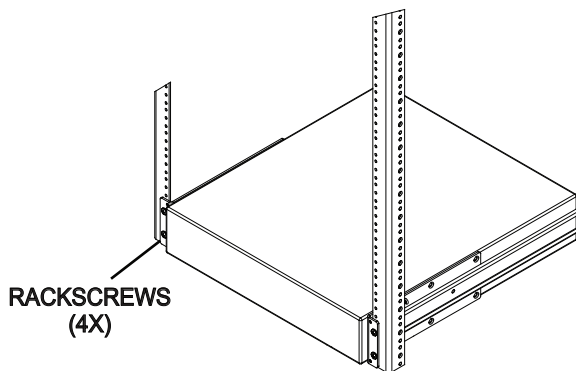

FIGURE D

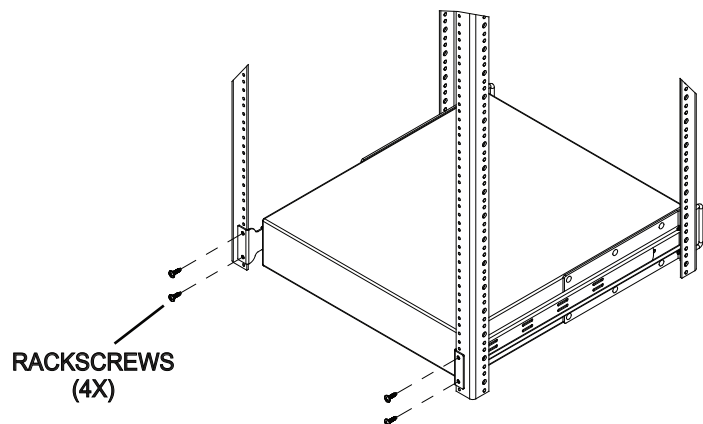
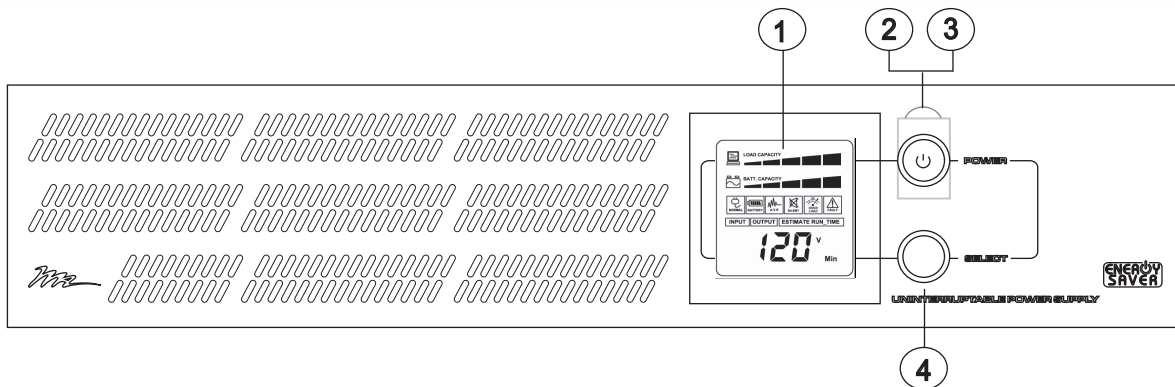

FIGURE E

FRONT PANEL DESCRIPTIONS



- ① **LCD display:** The LCD display indicates a variety of UPS operational conditions (see page 14 for LCD display definitions).
- ② **Power Switch:** On/off switch to turn UPS on and off.
- ③ **Power on indicator:** Indicates the UPS is turned on.
- ④ **LCD display toggle button:** Toggles between a variety of UPS operational conditions (see page 14).

REAR PANEL DESCRIPTIONS - BANK OUTLETS

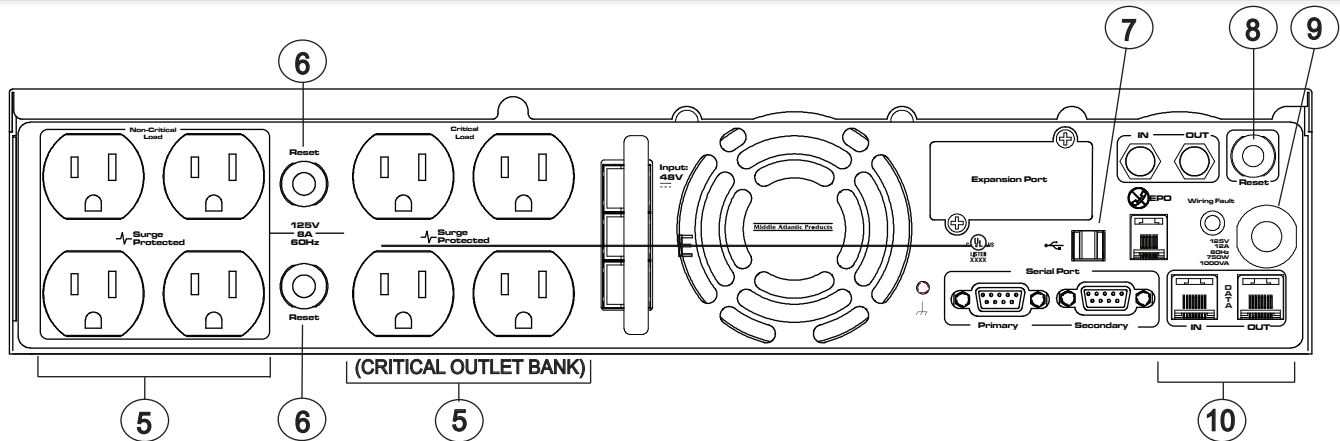

- ⑤ **AC Outlets:** All AC outlets provide connected equipment with AC line power, surge protection and line noise filtering during normal operation. Automatic voltage regulation corrects low voltage and high voltage conditions without using battery power. All outlets provide battery power during blackouts and severe brownout or severe high voltage conditions. The Non-Critical Load outlet bank can be configured to automatically shut down during a power outage event providing longer up-time for equipment plugged into the Critical Load outlet bank.
- ⑥ **AC Output circuit breakers:** Resettable circuit breakers provides AC output overload protection.
- ⑦ **USB port:** Connects UPS to your computer via the supplied USB cable for UPS setup, configuration and unattended shutdown in the event of a power failure. For use with the supplied Middle Atlantic Power Manager software. **(Please Note: The USB and Serial ports may not be used simultaneously)**
- ⑧ **Input circuit breaker:** Resettable circuit breaker provides input overload protection.
- ⑨ **Input power cord:** Heavy-duty permanently attached SignalSafe™ power cord, connects UPS to mains power.
- ⑩ **Communication protection ports RJ11/RJ45:** Protects against surges on a single phone, fax, modem or Ethernet network lines.

REAR PANEL DESCRIPTIONS - BANK OUTLETS (CONTINUED)

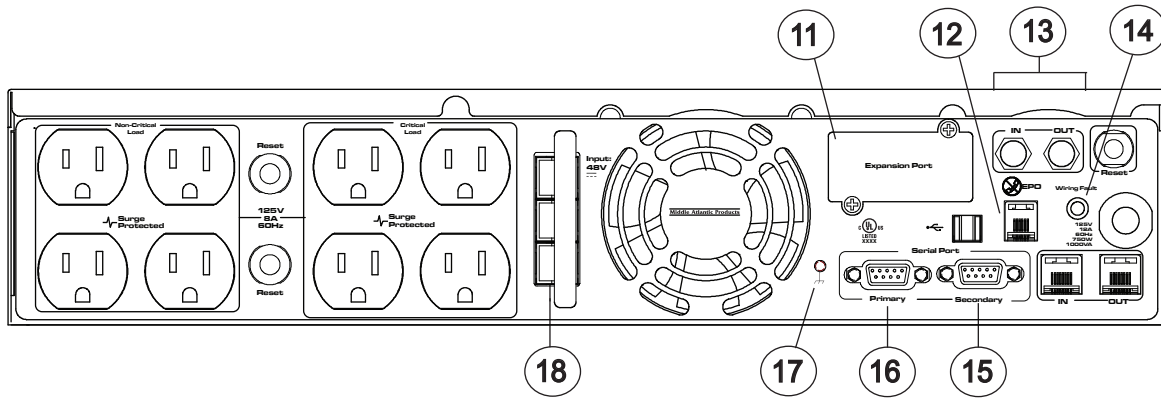

- ① **Expansion Port:** Slot for Network Interface Card (NIC). Part Number UPS-IPCARD. (See pg 11 - 13 for installation steps)
- ② **EPO (Emergency Power Off) Port:** The EPO port may be used to connect the UPS to a contact closure switch or control system to enable emergency shutdown (see page 15).
- ③ **Coax/Cable/DSS Surge Protection:** The Coax/Cable/DSS surge protection ports will provide surge protection to cable modem, CATV converter or DSS receiver.
- ④ **Site Wiring Fault Input LED Indicator:** This LED will illuminate to warn the user that a wiring problem exists within the AC mains electrical supply receptacle, such as reversed wiring. If illuminated, disconnect all equipment and contact an electrician to ensure the outlet is properly wired.

SERIAL PORT PRIMARY CONNECTOR PINOUT

Pin No	Description
1	Indicates battery condition. If battery low condition occurs, pin 1 is (low), otherwise pin 1 will be (high).
3	Ground. Connect to ground (common) of control system I/O.
4/5	Connect Pin4 with Pin7 and Pin5 with Pin3 for 12-15 second to trigger UPS S/D sequence on inverter mode.
7	+9VDC to + 12VDC must be applied to pin 7 from control system I/O in order for analog communication.
8	Indicates utility power condition. If a power failure occurs pin 8 is (low) otherwise pin 8 is (high).

Note: Primary DB-9 supports RS-232 as well as analog contact operation

- ⑤ **Serial Port Secondary I/O:** Analog input/output pinout shown below will provide status for remote monitoring of the UPS.
- ⑥ **Serial Port Primary:** The serial port primary allows for communication with a PC (through RS232) or a control system. **(Please Note: The USB and Serial ports may not be used simultaneously)**
- ⑦ **Ground stud:** Supplemental Bonding Point. Bonding of this point to the equipment and/or enclosure helps ensure optimum performance of the electronic system.
- ⑧ **External Battery Pack Connector:** Use to connect the optional MAP external battery pack (Part No. UPS-EBPR) for extended UPS runtime. A maximum of ten (10) battery packs can be daisy-chained together.

REAR PANEL DESCRIPTIONS - INDIVIDUAL OUTLETS

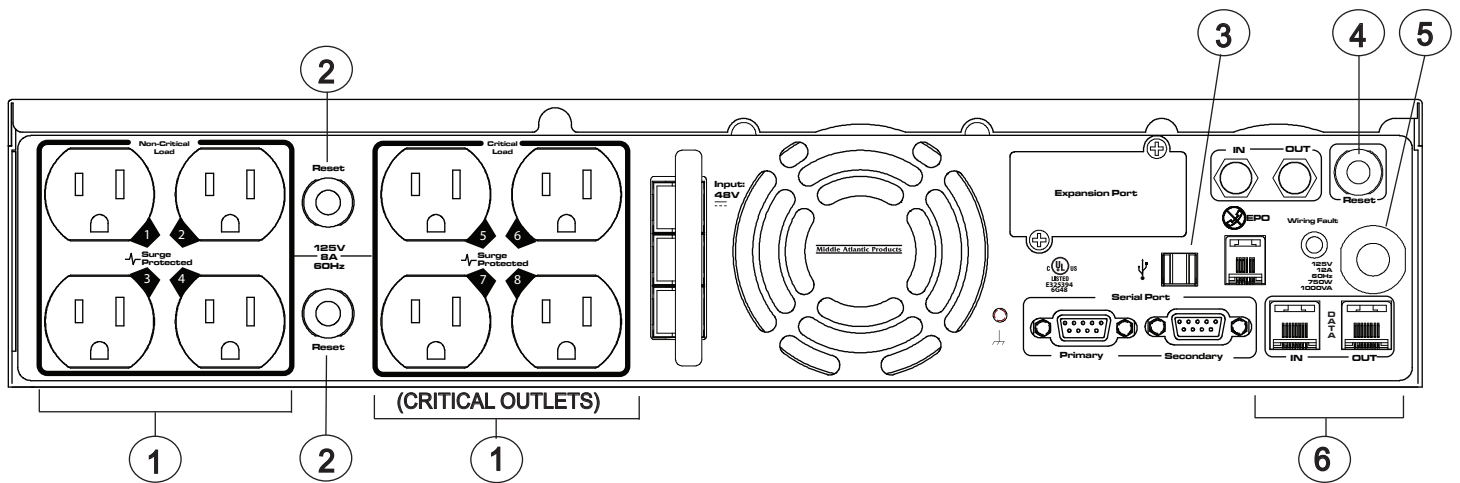

- 1 AC Outlets (Individually Controlled):** All AC outlets provide connected equipment with AC line power, surge protection and line noise filtering during normal operation. Automatic voltage regulation corrects low voltage and high voltage conditions without using battery power. All outlets provide battery power during blackouts and severe brownout or severe high voltage conditions. The Non-Critical Load outlets can be configured to automatically shut down during a power outage event providing longer up-time for equipment plugged into the Critical Load outlets.
- 2 AC Output circuit breakers:** Resettable circuit breakers provides AC output overload protection.
- 3 USB port:** Connects UPS to your computer via the supplied USB cable for UPS setup, configuration and unattended shutdown in the event of a power failure. For use with the supplied Middle Atlantic Power Manager software. **(Please Note: The USB and Serial ports may not be used simultaneously)**
- 4 Input circuit breaker:** Resettable circuit breaker provides input overload protection.
- 5 Input power cord:** Heavy-duty permanently attached SignalSafe™ power cord, connects UPS to mains power.
- 6 Communication protection ports RJ11/RJ45:** Protects against surges on a single phone, fax, modem or Ethernet network lines.

REAR PANEL DESCRIPTIONS - INDIVIDUAL OUTLETS (CONTINUED)

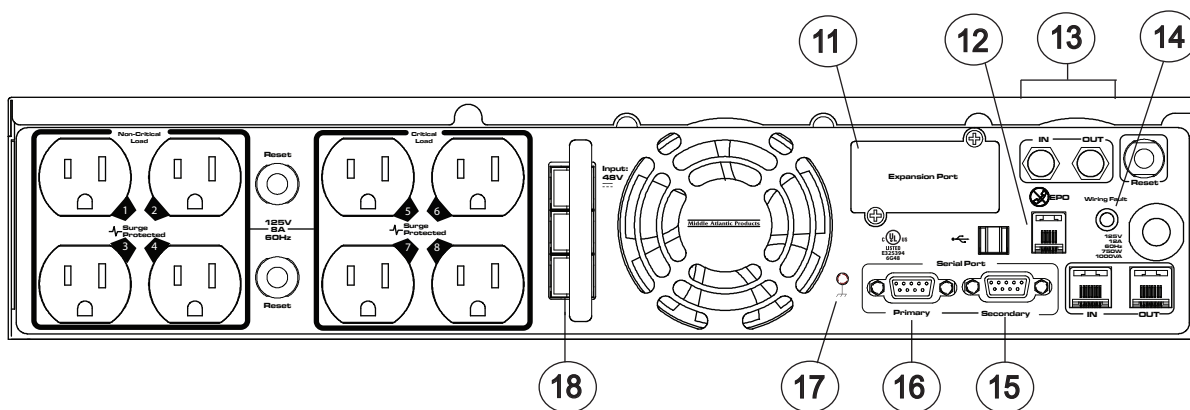

- 11 **Expansion Port:** Slot for optional Network Interface Card (NIC). Part Number UPS-IPCARD. (See pg 11 -13 for installation steps).
- 12 **EPO (Emergency Power Off) Port:** The EPO port may be used to connect the UPS to a contact closure switch or control system to enable emergency shutdown (see page 15).
- 13 **Coax/Cable/DSS Surge Protection:** The Coax/Cable/DSS surge protection ports will provide surge protection to cable modem, CATV converter or DSS receiver.
- 14 **Site Wiring Fault Input LED Indicator:** This LED will illuminate to warn the user that a wiring problem exists within the AC mains electrical supply receptacle, such as reversed wiring. If illuminated, disconnect all equipment and contact an electrician to ensure the outlet is properly wired.

SERIAL PORT SECONDARY CONNECTOR PINOUT

Pin No	Description
1	Indicates battery condition. If battery low condition occurs, pin 1 is (low), otherwise pin 1 will be (high).
3	Ground. Connect to ground or common of control system I/O.
7	+9VDC to + 12VDC must be applied to pin 7 from control system I/O in order for analog communication.
8	Indicates utility power condition. If a power failure occurs pin 8 is (low) otherwise pin 8 is (high).

- 15 **Serial Port Secondary I/O:** Analog input/output pinout shown below will provide status for remote monitoring of the UPS.
- 16 **Serial Port Primary:** The serial port primary allows for communication with a PC (through RS232) or a control system. **(Please Note: The USB and Serial ports may not be used simultaneously)**
- 17 **Ground stud:** Supplemental Bonding Point. Bonding of this point to the equipment and/or enclosure helps ensure optimum performance of the electronic system.
- 18 **External Battery Pack Connector:** Use to connect the optional MAP external battery pack (Part No. UPS-EBPR) for extended UPS runtime. A maximum of ten (10) battery packs can be daisy-chained together.

SETTING UP UPS-IPCARD

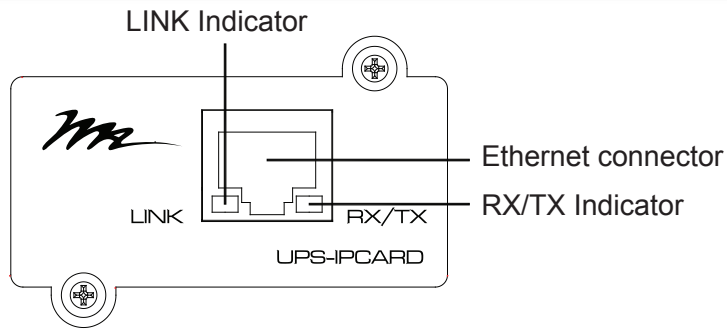

Definitions for LED Indicators

Link LED color	Condition
Off	The UPS Network Interface Card is not connected to the Network or the UPS Network Interface Card power is off
On (Yellow)	The UPS Network Interface Card is connected to the Network
RX/TX LED color	
Off	The UPS Network Interface Card power is off
On (Green)	The UPS Network Interface Card power is on
Flashing	- Receiving/transmitting data packet - Reset completed

Configuring the IP address for the Middle Atlantic Network Interface Card

Method 1: Using the SNMP Card Configuration Tool

- 1) Install the SNMP Card Configuration Tool from the included CD. It is located on the CD in the \tools\network folder. Double click the installation file "MAP_SNMP_Setup.msi" to begin the installation.
- 2) After the installation is complete, run the "Middle Atlantic UPS-IPCARD Setup Utility" program. Under "All Programs", select "Middle Atlantic Products > UPS-IPCARD".
- 3) The main screen of the SNMP Card Configuration Tool program is shown in **(FIGURE A)**. The configuration tool will display all Middle Atlantic UPS Network Interface Cards present on the network. Click "Refresh" to search for newly added devices

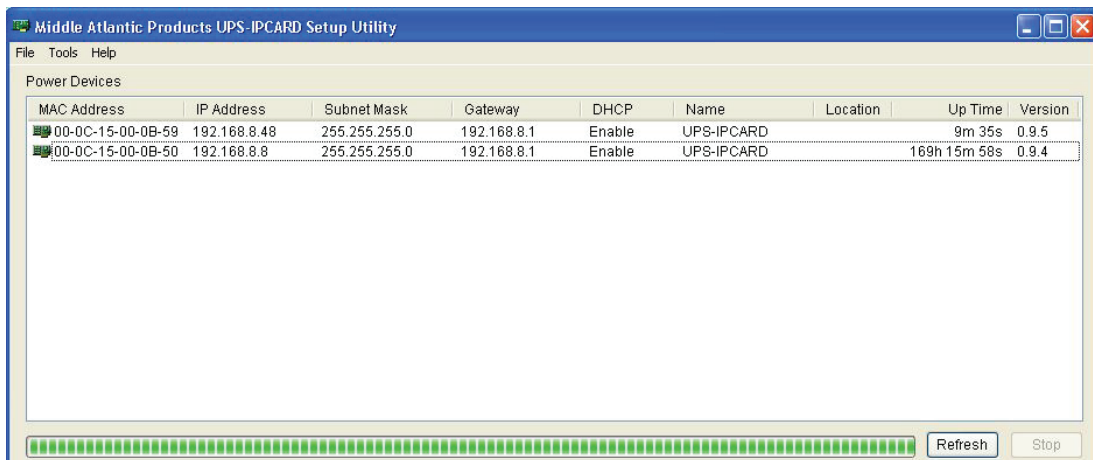

(FIGURE A)

SETTING UP UPS-PCARD (CONTINUED)

- 4) Select the SNMP card you are setting up. Click on the Tools menu and select “Device Setup” or double click the SNMP card you want to configure.
- 5) You can modify the IP Address, Subnet Mask, and Gateway address for the Device MAC Address listed in the Device Network Settings window, as shown in **(FIGURE B)**. The default IP Address is 192.168.20.177, the default Subnet Mask is 255.255.255.0.

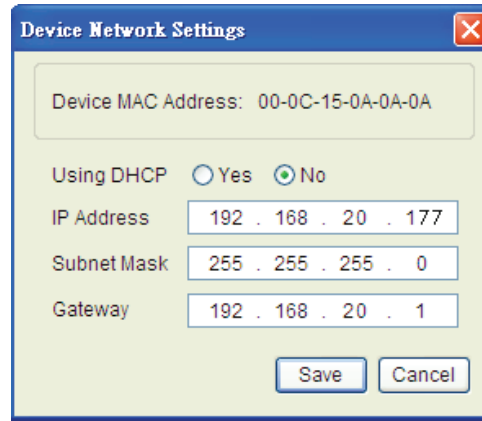

The screenshot shows a dialog box titled "Device Network Settings" with a close button (X) in the top right corner. The dialog contains the following fields and controls:

- Device MAC Address: 00-0C-15-0A-0A-0A
- Using DHCP: Yes No
- IP Address: 192 . 168 . 20 . 177
- Subnet Mask: 255 . 255 . 255 . 0
- Gateway: 192 . 168 . 20 . 1
- Buttons: Save, Cancel

(FIGURE B)

- 6) Modify the IP, subnet mask or gateway address. Enter the new addresses into the corresponding fields.
- 7) You will need to enter a password for the SNMP card in the authentication window as shown in **(FIGURE C)**. Default user name: **admin**. Default password: **admin**.

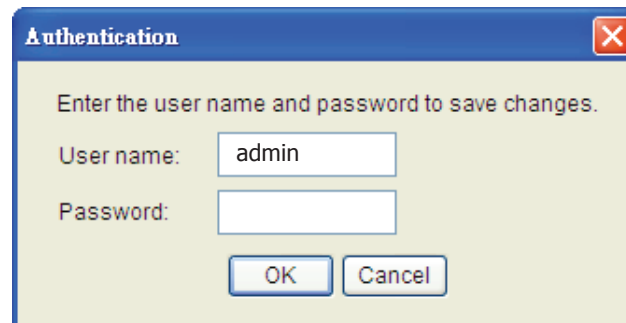

The screenshot shows a dialog box titled "Authentication" with a close button (X) in the top right corner. The dialog contains the following fields and controls:

- Enter the user name and password to save changes.
- User name: admin
- Password: (empty field)
- Buttons: OK, Cancel

(FIGURE C)

- 8) If the IP address is successfully set, you will see a message that the IP setup is okay. **(FIGURE D)**

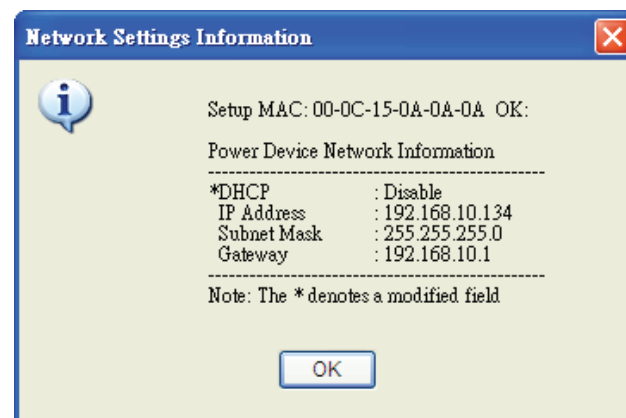

The screenshot shows a dialog box titled "Network Settings Information" with a close button (X) in the top right corner. The dialog contains the following information:

- Setup MAC: 00-0C-15-0A-0A-0A OK:
- Power Device Network Information
- *DHCP : Disable
- IP Address : 192.168.10.134
- Subnet Mask : 255.255.255.0
- Gateway : 192.168.10.1
- Note: The * denotes a modified field
- Button: OK

(FIGURE D)

SETTING UP UPS-IPCARD (CONTINUED)

Method 2: Using a Command Prompt

- 1) Obtain the MAC address from the label on the UPS Network Interface Card rear panel. Each UPS Network Interface Card has a unique MAC address.
- 2) Use the ARP command to set the IP address. Example: To assign the IP Address 192.168.20.240 for the UPS Network Interface Card, which has a MAC address of 00-0C-15-00-00-01 you will type in the following command prompt from a PC connected to the same network as the UPS Network Interface Card. (1) Type in “arp-s 192.168.20.240 00-0C-15-00-00-01” then press **'Enter'**.
- 3) Use the Ping command to assign a size of 123 bytes to the IP. (1) Type in “ping 192.168.20.240 -l 123” then press **'Enter'**.

Method 3: Login from a Web Interface

- 1) Type the IP address of the UPS in your web browser and hit **'Enter'** to access the UPS.

There are two user account types.

- Administrator (default username : **admin** ; default password : **admin**)
- Viewer (default username : **guest** ; default password : **guest**)

The administrator can access all functionality including enable/disable the guest account. The guest account can access “read only” functionality but can not control or change any settings

- 2) The IP address can be changed by accessing the system>tcp/ip menu. Refer to the MAP UPS-IPCARD User's Manual for more detail (I-00453).

LCD DISPLAY DEFINITIONS

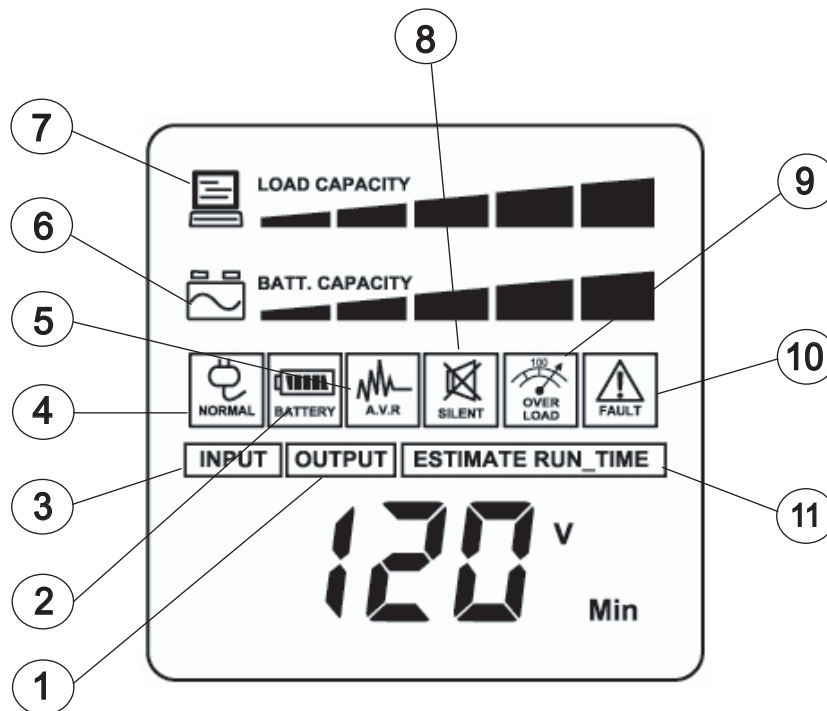

- 1 Output Meter:** Displays the output AC voltage, frequency and wattage that the UPS is providing.
- 2 Battery Icon:** When operating on battery, this icon appears and an alarm sounds (two short beeps followed by a pause) indicating the UPS is operating from its internal battery.
- 3 Input Voltage Meter:** Measures the incoming AC voltage that the UPS is receiving from the mains power connection.
- 4 Normal Icon:** This icon appears when the UPS is functioning normally.
- 5 AVR (Automatic Voltage Regulator):** This icon appears whenever the UPS is automatically correcting low or high input AC line voltage without using battery power. This is a normal, automatic operation of the UPS, no operator action is required.
- 6 Battery Capacity Meter:** This meter displays the approximate charge level (in 20% shaded increments) of the UPS's internal battery and external battery.
- 7 Load Capacity Meter:** This meter displays the approximate output load level (in 20% shaded increments) of the UPS's AC outlets
- 8 Silent Mode Icon:** This icon appears whenever the UPS is in silent mode. The buzzer can be turned on or off by the user and does not beep during silent mode until the battery reaches low capacity.
- 9 Overload Icon:** This icon appears and an alarm sounds to indicate that the AC outlets are overloaded. To clear the overload, first turn the power off on each equipment and unplug from the AC outlets one at a time, until the overload icon disappears and the alarm stops.
- 10 Fault Icon:** This icon appears if there is a problem with the UPS. Contact Middle Atlantic Products at 1-800-266-7225 for further help and support.
- 11 Estimate Runtime:** This displays the runtime estimate of the UPS with the current battery capacity and load.

BATTERY CHARGING

The UPS is shipped from the factory with its internal battery fully charged. However, the battery may lose some charge during shipping and storage. Recharging the battery for at least four hours is recommended to ensure that the battery's maximum charge capacity is achieved.

The UPS is equipped with an auto-charge feature. When the UPS is plugged into mains AC supply voltage, the battery will automatically recharge (the battery will charge with the UPS either turned on or off). To maintain optimal battery charge, leave the UPS plugged into an AC outlet at all times.

SELF TEST

The UPS features a built-in self test which verifies the operation of the UPS and the condition of the battery. During self test, the UPS is powered by its internal battery.

- 1) With the UPS turned on, press and hold the Select button for approximately 5 seconds until the UPS starts to beep. Release the button.
- 2) The Battery icon will appear on the LCD Display. After approximately 10 or more seconds, the UPS will revert back to normal mode.

EPO (EMERGENCY POWER OFF) PORT CONNECTION

This feature is for those applications that require connection to an Emergency Power Off (EPO) circuit in case of fire or other emergency situation. When the UPS is connected to this circuit, it enables emergency shutdown of the UPS's inverter. Using the supplied gray cable, connect the EPO port of your UPS to a user-supplied normally closed or normally open switch according to the circuit diagram shown below. Press the Power switch twice to turn on the UPS after making the connections.

OPTION 1: USER SUPPLIED NORMALLY CLOSED SWITCH

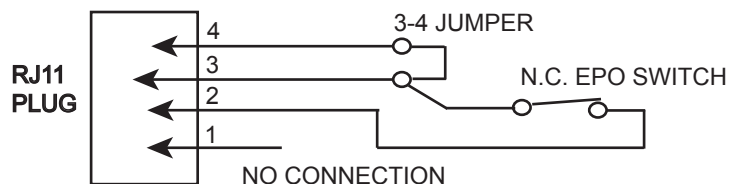

OPTION 2: USER SUPPLIED NORMALLY OPEN SWITCH

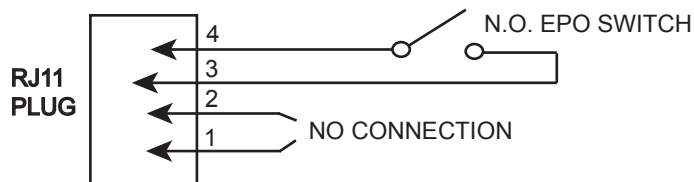

OPERATION

⚠ CAUTION: DO NOT plug a laser printer, copier, space heater, vacuum, paper shredder or other large electrical device into the UPS. The power demands of these devices will overload and possibly damage the UPS.

⚠ ATTENTION: NE PAS brancher une imprimante laser, copieur, appareil de chauffage, vide, destructeur de papier ou d'un autre grand appareil électrique sur l'onduleur. Les demandes d'énergie de ces appareils seront surcharger et éventuellement endommager les UPS.

1) Plug the UPS into a grounded wall receptacle. Ensure the wall receptacle is protected by a fuse or circuit breaker and does not service other equipment with large electrical demands (i.e. air conditioner, refrigerator, copier, etc.)

2) Press the Power Switch to turn the UPS on. The Power On Indicator will illuminate.

NOTE: If an overload is detected, an audible alarm will sound and the UPS will emit one long beep. To correct this, first turn the power off on a piece of equipment and unplug that piece of equipment from the UPS. Wait approximately 10 seconds and reconnect the piece of equipment to the UPS and turn it on. If after reconnecting, the overload alarm sounds, turn off the piece of equipment, remove from the UPS and connect it to another power source.

GENERAL STATUS MODE

1) Press the Select button on the front panel to view each UPS status item listed in Table 1. Each item will display in the order shown.

NOTE: The LCD display backlight will automatically turn off if the Select button is not pressed for more than 30 seconds.

ORDER	STATUS ITEM	UNIT
1	Input Voltage	V
2	Output Voltage	V
3	Output Frequency	Hz
4	Load	Kw
5	Estimate Run Time	Min
6	Load Capacity	%
7	Battery Capacity	%
8	Temperature	°C
9	Temperature	°F

TABLE 1

SETTING UP UPS-PCARD (CONTINUED) FUNCTIONS SETUP MODE

1) Refer to Table 3 for a list of the functions which are configurable.

2) To enter setup mode, press and hold the Select button on the front panel for approximately 5 or more seconds. The UPS will start beeping, release button after six beeps. The LCD display will show six icons (Normal, Battery, A.V.R., Silent, Overload, and Fault).

NOTE: 1) If there is no user action for more than 30 seconds, the LCD backlight will turn off and the UPS will return to the "General Status Mode".

2) The user can return to "General Status Mode" at anytime by waiting for the LCD backlight to turn off or by pressing and holding the Select button for approximately 10 or more seconds.

3) Pressing the Select button will display each function listed in Table 2 in the order given.

ORDER	FUNCTION	UNIT
1	Delay Time	Min
2	Number of Expansion Battery Packs	1-10
3	Static Frequency Tolerance	Hz
4	Slew Rate	Hz
5	Battery Shutdown Voltage	V
*6	Firmware version	

* Not configurable **TABLE 2**

4) To change functions, press and hold the Select button until the six icons are blinking on and off. Press the Select button to enter the desired value.

5) To save the value, press and hold the Select button for approximately 4 seconds. The LCD display will return to the General Status Mode Input Voltage Display. Repeat steps 1 through 4 each time any of the function values are to be changed.

FUNCTIONS SETUP MODE (CONTINUED)

FUNCTION	DESCRIPTION	DEFAULT SETTING
Delay Time	The time delay switching from battery mode to line mode. There are 9 different settings: (0, 0.5, 1.0, 1.5, 2.0, 2.5, 3.0, 3.5, 4.0) seconds	0
Number of Expansion Battery Packs	This function defines the number of external battery packs connected to the UPS: (one - ten)	0 (no external battery packs connected)
Static Frequency Tolerance	Setting is dependant on the quality of the supplied AC power. There are 4 different settings: (1%, 2%, 4% and 6%)	6%
Slew Rate	Indicates the tolerance of a device in accepting frequency variations. The lower slew rate results in less tolerance but better protection for the connected loads. There are 5 different settings: (0.25 Hz, 0.5 Hz, 1 Hz, 2 Hz, 4 Hz)	4 Hz
Battery Shutdown Voltage	Adjusts the UPS shutdown point according to the remaining battery voltage. There are five different settings: 38VDC, 39VDC, 40VDC, 41VDC and 42VDC Please note that selecting a higher shutdown voltage will extend battery life, but decrease on-battery run-time	40 VDC

TABLE 3. Configurable Parameters

BATTERY REPLACEMENT

Contact your dealer or call the number in this manual for information on battery replacement. Read and follow the IMPORTANT SAFETY INSTRUCTIONS before servicing the battery. Service the battery under the supervision of personnel who are knowledgeable about batteries and their precautions. Servicing of the battery can only be performed by trained personnel.



IMPORTANT SAFETY INSTRUCTIONS READ AND SAVE THESE INSTRUCTIONS



The lightning flash with the arrowhead symbol, within an equilateral triangle, is intended to alert the user to the presence of uninsulated dangerous voltage within the product's enclosure that may be of sufficient magnitude to constitute a risk of electric shock.



The exclamation point within an equilateral triangle is intended to alert the user to the presence of important operating and maintenance (servicing) instructions in the literature accompanying the product.



WARNING: Risk of battery explosion, if battery is replaced by an incorrect type or rating.



WARNING: Do not open or mutilate the batteries. Electrolyte is harmful to the skin and eyes and may be toxic.



WARNING: A battery can present a high risk of short circuit current and electrical shock.



WARNING: The battery may present the risk of electrical shock. Do not dispose of batteries in a fire, as they may explode. Follow all local ordinances regarding proper disposal of batteries.



CAUTION: To reduce the risk of fire, connect only to a circuit provided with 20 Amperes maximum branch overcurrent protection in accordance with the National Electrical Code, ANDI/NFPA 70.



CAUTION: Use only the specified type of battery. See your dealer for replacement batteries.

The following precautions should be observed before replacing the battery:

1. Remove all watches, rings or other metal objects.
2. Only use tools with insulated handles.
3. Do not lay tools or metal parts on top of battery or any terminals.
4. Wear rubber gloves and boots.
5. Determine if the battery is inadvertently grounded. If inadvertently grounded, remove the ground source. **CONTACT WITH GROUNDED BATTERY CAN RESULT IN ELECTRICAL SHOCK!** The likelihood of such shock will be reduced if such grounds are removed during installation and maintenance (applicable to a UPS and a remote battery supply not having a grounded circuit.)

BATTERY REPLACEMENT (CONTINUED)

Contactez votre revendeur ou appeler le numéro dans ce manuel pour obtenir des informations sur le remplacement de la batterie. Lire et suivez les consignes de sécurité avant l'entretien de la batterie. Service uniquement la batterie avec la supervision du personnel avec bien informé sur les batteries et leurs précautions. Entretien de la batterie ne peut être effectuée par un personnel qualifié.



CONSIGNES DE SÉCURITÉ IMPORTANTES LIRE ET CONSERVER CES INSTRUCTIONS



L'éclair avec le symbole de flèche dans un triangle équilatéral est destiné à alerter l'utilisateur de la présence d'une tension dangereuse non isolée dans l'enceinte du produit qui peut être d'une ampleur suffisante pour constituer un risque de choc électrique pour les personnes



Le point d'exclamation dans un triangle équilatéral est destiné à alerter l'utilisateur de la présence d'importants instructions d'opération et de maintenance (entretien) dans la documentation accompagnant l'appareil



AVERTISSEMENT: Risque d'explosion de la batterie, si la batterie est remplacée par un type incorrect ou d'une qualification.



AVERTISSEMENT: N'ouvrez pas ou ne mutilez pas les batteries. Le matériel libéré est nocif à la peau et aux yeux et peut être toxique.



AVERTISSEMENT: Une batterie peut présenter un risque élevé de courant de court-circuit ou un choc électrique.



AVERTISSEMENT: La batterie peut présenter un risque de choc électrique. Ne jetez pas les batteries au feu, car elles peuvent exploser. Suivez tous les règlements locaux concernant l'élimination adéquate des piles.



ATTENTION: Pour réduire le risque d'incendie, relie seulement à un circuit équipé de 20 ampères de branche de circuit de protection maximum de surintensité selon le code électrique national, ANSI/NFPA 70.



ATTENTION: Utilisez uniquement le type de pile spécifié. Voir votre concessionnaire pour les batteries de remplacement.

Les précautions suivantes doivent être respectées avant de remplacer la batterie:

1. Retirez toutes les montres, bagues ou autres objets métalliques.
2. Utilisez uniquement des outils isolés.
3. Ne pas poser d'outils ou de pièces métalliques sur le dessus de la batterie ou des terminaux.
4. Portez des gants et des bottes en caoutchouc.
5. Déterminer si la batterie est relié à la terre par inadvertance. Si la terre par inadvertance, retirez le terrain la source. CONTACT AVEC LA BATTERIE masse peut provoquer un choc électrique! le la probabilité d'un tel choc sera réduite si ces motifs sont supprimés lors de l'installation et maintenance (applicable à un onduleur et une alimentation par batterie à distance ne pas avoir un circuit à la terre.)

BATTERY REPLACEMENT (CONTINUED)



CAUTION: The battery is heavy, use caution when removing
ATTENTION: LA BATTERIE EST LOURD, SOYEZ PRUDENT LORSQUE VOUS RETIREZ



- 1) Power off the unit and disconnect it from its AC power source.
- 2) Remove the front panel by removing six screws then grasping it on the left hand side and pulling it away from the unit. Remove the right side of the panel to detach it from the unit.

REMOVE FRONT PANEL

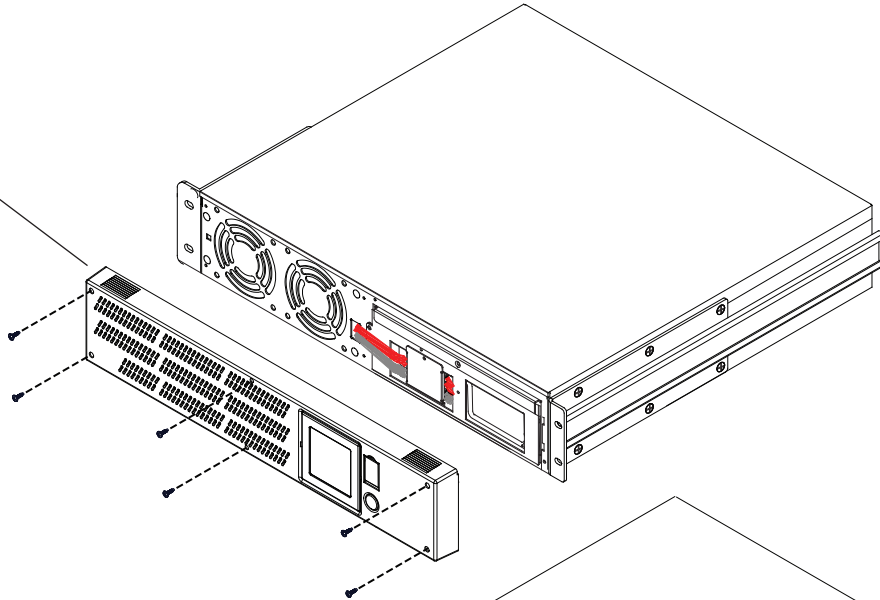

- 3) Remove the retaining screws securing the cable protection cover to the UPS and remove the cover.

REMOVE CABLE PROTECTION COVER

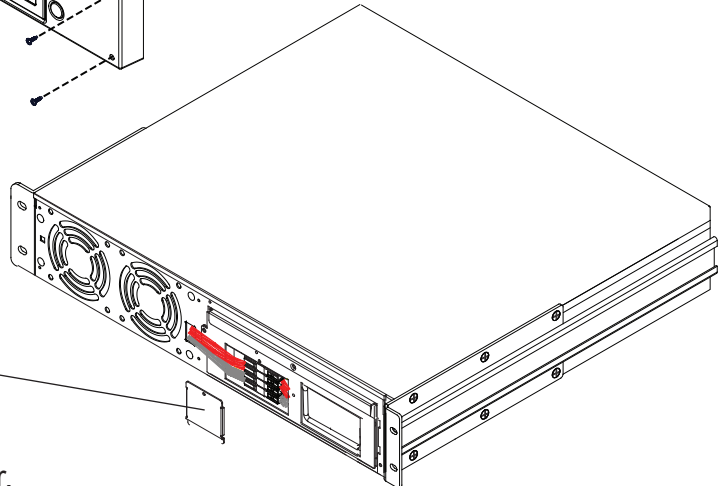

- 4) Disconnect the cable connectors from each other.

DISCONNECT CABLE CONNECTORS

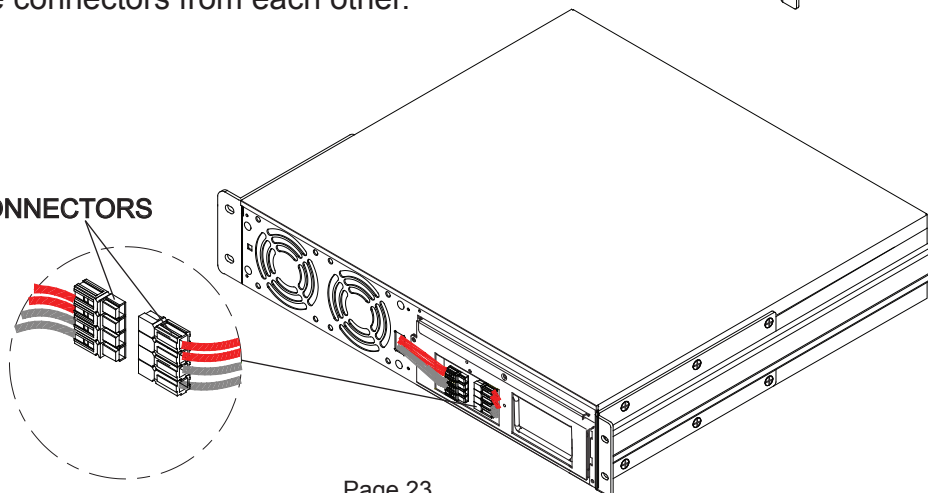

BATTERY REPLACEMENT (CONTINUED)

- 5) Remove three battery retaining screws (2 on left side, and 1 on the right side) and pull the battery out using the handle.

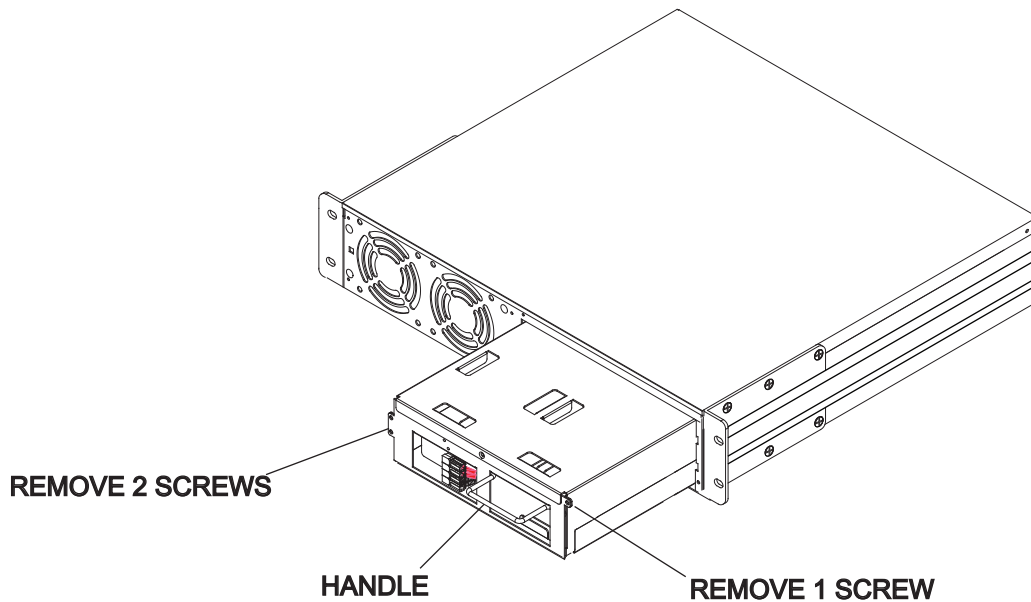

- 6) Insert replacement battery (Part No. UPS-RBP) and perform steps 2 - 4 in reverse. To reinstall the faceplate, reinstall six screws.

- Recharge the battery for 4-8 hours to ensure that the UPS meets the expected on-battery runtime -

OPTIONAL EXTERNAL BATTERY

All UPS models feature a connector that accepts an optional external battery pack (Part Number UPS-EBPR, sold separately) that provides additional runtime and increases UPS battery recharge time. The external battery packs can be daisy chained up to a maximum of ten battery packs.

TROUBLESHOOTING

Problem	Possible Cause	Solution
Outlets do not provide power to equipment.	<ol style="list-style-type: none"> 1. Circuit breaker has tripped due to an overload. 2. Batteries are discharged 3. Unit has been damaged by a surge or spike. 4. Non critical outlets have turned off automatically due to an overload. 	<ol style="list-style-type: none"> 1. Turn the UPS off and unplug at least one piece of equipment. Wait 10 seconds, reset the circuit breaker, and then turn on the UPS. 2. Recharge the unit for at least 4 hours. 3. Contact Middle Atlantic Products at 1-800-266-7225. 4. Push the bottom Reset button to turn on the Non critical outlets.
The UPS does not perform the expected runtime.	<ol style="list-style-type: none"> 1. Battery is not fully charged. 2. Battery is degraded. 	<ol style="list-style-type: none"> 1. Recharge the battery by leaving the UPS plugged in. 2. Contact Middle Atlantic Products about replacement batteries at 1-800-266-7225.
The UPS will not turn on.	<ol style="list-style-type: none"> 1. The on/off switch is designed to prevent damage by rapidly turning it on and off. 2. The UPS is not connected to an AC outlet. 3. The battery is degraded. 4. Mechanical problem. 	<ol style="list-style-type: none"> 1. Turn the UPS off. Wait 10 seconds and then turn the UPS on. 2. The UPS must be connected to a 110/120V outlet. 3. Contact Middle Atlantic Products about replacement batteries at 1-800-266-7225. 4. Contact Middle Atlantic Products at 1-800-266-7225.
Middle Atlantic Power Manager software is inactive	<ol style="list-style-type: none"> 1. The serial cable or USB cable is not connected. 2. The cable is connected to the wrong port. 3. The unit is not providing battery power. 4. The serial cable is not the cable that was provided with the unit. 	<ol style="list-style-type: none"> 1. Connect the cable to the UPS. You must use the cable that came with the UPS. 2. Ensure that either the USB or DB-9 cable is connected to the correct port on both the UPS and the computer. 3. Shutdown your computer and turn the UPS off. Wait 10 seconds and turn the UPS back on. This should reset the unit. 4. You must use the cable included with the unit for the software.

TROUBLESHOOTING NETWORK INTERFACE CARD

Problem	Solution
Unable to configure the UPS Network Interface Card by method 1 or method 2.	<ol style="list-style-type: none">1. Check the LED status, the normal condition is both yellow and green led is on. If green LED is off: Check if the UPS Network Interface Card is properly seated in the UPS and the UPS power is on. If yellow LED is off: Check if the network connection is valid.2. Check if the operated PC is on the same physical network as UPS Network Interface Card is.
Unable to ping the UPS Network Interface Card.	<ol style="list-style-type: none">1. Use method 1 and method 2 to get correct IP address of the UPS Network Interface Card.2. If the operated PC is on the different physical network from the UPS Network Interface Card, verify the setting of subnet mask and the IP address of gateway.
Forgotten user name and password.	Please refer to the “Reset to Default Setting/Recover from a Forgotten Password” section in the UPS-IPCARD user manual (I-00453).

TECHNICAL SPECIFICATIONS

MODEL	UPS-1000R Series	UPS-2200R Series
Capacity (VA)	1000	2150
Capacity (Watts)	750	1650
INPUT		
Cord Length & Plug Type	9ft. & NEMA 5-15P	9ft. & NEMA 5-20P
Input Voltage Range	80 VAC - 150 VAC	
Input Frequency Range	50/60 Hz +/- 3 Hz (auto sensing)	
OUTPUT		
On Battery Output Voltage	Pure Sine Wave at 120 VAC +/- 7%	
On Battery Output Frequency	50/60 Hz +/- 1%	
Transfer Time (Typical)	4 ms	
Overload Protection	On Utility: Circuit Breaker, On Battery: Internal Current Limiting	
SURGE PROTECTION AND FILTERING		
Lighting/Surge Protection	Yes	
Internet Ready (DSL/Phone/Fax/Modem Protection)	RJ11/RJ45 (One In/One Out)	
PHYSICAL		
Output Receptacles	(8) NEMA 5-15R	(8) NEMA 5-20R
Dimensions: in. (cm)	2U Rack, 17.05 x 3.5 x 18.9 (43.3 x 8.8 x 48)	
Weight: Lb. (Kg)	68.3 (31)	76.7 (34.8)
BATTERY		
Sealed Maintenance Free Lead Acid Battery	12V/9.0AH x 4	
Hot Swappable External Battery	Yes	

TECHNICAL SPECIFICATIONS (CONTINUED)

Model	UPS-1000R Series	UPS-2200R Series
Warning Diagnostics		
Indicators	Power On, Wiring Fault, LCD Display (Using Battery, AVR, Load Level, Battery Level)	
Audible Alarms	On Battery, Low Battery, Overload	
Environmental		
Operating Temperature	32° F to 104° F (0° C to 40° C)	
Operating Relative Humidity	0 to 95% Non-Condensing	
Communication		
Power Manager™ Software	Windows 98/ME/NT/2000/XP/Vista/7	
Management		
Self-Test	Manual Self-Test	
Auto-Charger/Auto-Restart	Yes	
COM Interface	True RS232 x1 + Analog I/O x 1	
Built-in USB Interface	Yes	

ESTIMATED RUNTIME

UPS-1000R SERIES ESTIMATED UNDER LOAD RUNTIME

NOTE: The runtime values listed below are the maximum values. The actual runtime will be determined by the value set through the 'Battery is Critically Low' option in the Power Manager Software. Refer to the Power Manger Software User Manual, page 6. Document number I-00343.

Load (VA)	120	240	360	480	600	720	840	960
Load (A)	1	2	3	4	5	6	7	8
Number of Batteries	ESTIMATED RUNTIME (In Minutes)							
0	102	51	34	26	20	17	15	13
1	561	283	190	143	114	94	80	69
2	1020	515	345	260	207	171	145	125
3	1479	747	501	377	300	249	211	181
4	1938	979	657	494	394	326	276	238
5	2397	1211	813	611	487	403	341	294
6	2856	1443	968	728	580	480	407	350
7	3315	1676	1124	845	674	557	472	406
8	3774	1908	1280	962	767	635	537	463
9	4233	2140	1435	1079	860	712	603	519
10	4692	2372	1591	1196	954	789	668	575

ESTIMATED RUNTIME (CONTINUED)

UPS-2200R SERIES ESTIMATED UNDER LOAD RUNTIME

NOTE: The runtime values listed below are the maximum values. The actual runtime will be determined by the value set through the 'Battery is Critically Low' option in the Power Manager Software. Refer to the Power Manger Software User Manual, page 6. Document number I-00343.

Load (VA)	120	240	360	480	600	720	840	960	1080	1200	1320	1440	1560	1680	1800	1920
Load (A)	1	2	3	4	5	6	7	8	9	10	11	12	13	14	15	16
Number of Batteries	ESTIMATED RUNTIME (In Minutes)															
0	102	51	34	26	20	17	15	13	11	10	9	9	8	7	7	6
1	561	283	190	143	114	94	80	69	60	53	47	42	37	33	29	26
2	1020	515	345	260	207	171	145	125	109	96	84	75	66	58	51	45
3	1479	747	501	377	300	249	211	181	158	139	122	108	95	84	74	64
4	1938	979	657	494	394	326	276	238	207	181	160	141	124	109	96	84
5	2397	1211	813	611	487	403	341	294	256	224	197	174	153	135	118	103
6	2856	1443	968	728	580	480	407	350	305	267	235	207	182	161	141	122
7	3315	1676	1124	845	674	557	472	406	353	310	272	240	212	186	163	142
8	3774	1908	1280	962	767	635	537	463	402	352	310	273	241	212	185	161
9	4233	2140	1435	1079	860	712	603	519	451	395	348	306	270	237	208	181
10	4692	2372	1591	1196	954	789	668	575	500	438	385	339	299	263	230	200

WARRANTY

For warranty information, refer to <http://www.middleatlantic.com/company/about-us.aspx#warranty>

Corporate Headquarters

Corporate Voice: 973-839-1011 - Fax: 973-839-1976 / International Voice: +1 973-839-8821 -

Fax: +1 973-839-4982

www.middleatlantic.com - info@middleatlantic.com

Middle Atlantic Canada

Voice: 613-836-2501 - Fax: 613-836-2690 / ca.middleatlantic.com -

customerservicecanada@middleatlantic.ca

Factory Distribution

USA: NJ - CA - IL Canada: ON

At Middle Atlantic Products we are always listening. Your comments are welcome.

Middle Atlantic Products is an ISO 9001 and ISO 14001 Registered Company.

WARRANTY REGISTRATION

IMPORTANT NOTE

Please register your purchase.
<http://www2.middleatlantic.com/ups/warranty/registration.aspx>



Middle Atlantic Products

what great systems are built on™

middleatlantic.com ■ 800.266.7225